

Abstract:

This paper describes the measurement of simple components using an AEA Technology network analyzer.

Introduction:

The method for measuring discrete components (inductors, resistors, and capacitors) requires the creation of a test jig. The type of jig used depends on the frequency range that the component will be tested at. Low frequency measurements can use a clip lead type of fixture, higher frequencies require a solder in design or elaborate spring clips. Defining the boundary between low and high frequencies involves many factors; experimentation with known components will determine if the clips leads fixture gives acceptable results.

Low Frequency:

For lower frequencies, use a lead set that has a coaxial connector on one end and clip leads on the other. One example of the clip lead cable would be AEA Technology PN 0070-1220 Or PN 0070-1221. The steps required to measure a component:

1. Attach lead set to S11 port on network analyzer.
2. Turn on power to network analyzer
3. Twist the leads of the lead set tightly together.
4. Set network analyzer center frequency and sweep width to cover the desired range of interest.
5. Set the plot types to resistance and reactance (other plot types may be used if desired).
6. If required, configure the network analyzer to display the L-C value (see Appendix A for model specific details)
7. Short the lead set together (connect clips to each other).
8. Note the impedance level(s). If these levels exceed the tolerance limits of what you want to measure, perform a cable null. You can adjust the value of the reference load by setting the characteristic Z (see analyzer manual for details)
9. The clip leads should maintain the same twist and clip spacing to the greatest extent possible during the 3 cable null steps and when connected to the component under test. Changing the lead twist and /or the clips spacing reduces the accuracy gained by the cable null.
10. When mechanical access of the component permits, shortening the lead length between the coaxial connector and the clip will reduce the bad effects of the leads. If you sometimes need longer leads, and other times need shorter leads, make two test lead sets.

High Frequency:

Sometimes the frequency of interest just will not permit the clip leads to be useful. Also, measuring small SMD components with clip leads is too awkward. A solder in fixture works best for these cases. An SMA bulkhead connector forms a good building block for an SMD fixture.

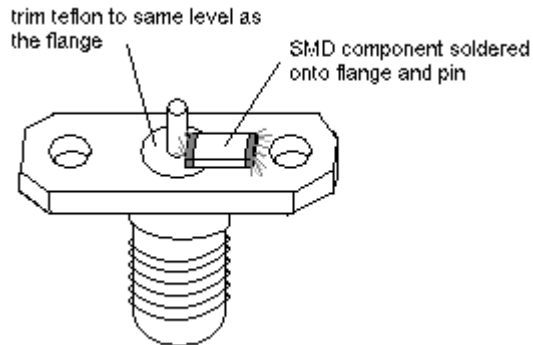

SMA Fixture:
Mount SMD components onto SMA connector

Following the example shown above, make three SMA fixtures for cable nulling, the first is left empty, the second shorts the pin to the flange, and the third has a load resistor (usually 50 ohms). These are easily interchanged as required by the cable null process. The component(s) under test use additional SMA fixtures, and are also easily attached and removed from the test set up. Depending on the model of network analyzer you have determines what adaptors to use to mate the SMA fixture to the network analyzer. A short section of semi rigid coax makes for a convenient way to position the fixtures comfortably. The SMA fixtures can mount directly onto the adaptor if desired.

To measure a component, follow steps 1, 2, 4, 5, and 6 for the low frequency procedure listed above. Replace the clip leads with the adaptor, semi rigid, and SMA fixtures. Do not skip the cable nulling.

Active Devices:

Some devices, like diodes, should be measured with a DC voltage or current applied. Feed the bias to the component with a resistor or RF coil that is large enough to not affect the component reading (resistance or reactance >10 times component reading). Build the circuit on an SMA fixture, or add the PCB containing the component under test to an SMA connector.

Conclusion:

The AEA series of network analyzer s provides a convenient and accurate method to measure discrete components

Appendix A:

Model	Model #	To see L or C	Plot types	Reference load set
Bravo	6014-5xxx	Third large number, 80 point plot	Resistance & Reactance	F5-Cable char. Enter value in ohms
Bravo II	6014-5250			
Bravo MRI	6015-5xxx	Must calculate from reactance		

Keywords: how to measure discrete components using network analyzer, network analyser, example measure components basics explained

Alternate Titles: how to measure discrete components using network analyzer, network analyser, measure components basics, measuring resistors explained, measuring capacitors explained, measuring inductors explained,