

**Abstract:**

This paper explains how to tune a coaxial stub, or measure the electrical length on a piece of coax using an AEA Technology network analyzer.

**Introduction:**

Coaxial stubs present a reactance to the system or circuit that they are connected to. In the case of antennae, the stub cancels out undesired reactance at the antenna and tunes it to resonance. Stubs behave like inductors or capacitors: as capacitors they withstand the high voltages that a transmitter generates, as inductors they reduce losses compared to wire wound elements.

This paper will cover how to measure, connect, terminate, and tune stubs using a network analyzer. Also the paper explains how to use a Smith chart to find its reactance.

**Discussion:**

Coaxial stubs may be either tuned to a specific application (in situ), or may be tuned to a predetermined length. In the first case, connect the network analyzer to the combination of stub and load. When tuning the stub to a preset length, only the stub connects to the network analyzer.

It is good practice to connect one end of the stub to a coaxial connector designed for the type of cable used by the stub. Omitting the connector, usually to save a few bucks, will cause measurement inaccuracies, and generally results in a poorly constructed stub that degrades rapidly with time. The stub, load, and feed line are connected together with a coaxial "Tee". For outdoor environment, the Tee should be weather proofed, and any coaxes that feed downward to the tee should use drip loops.

When tuning a stub, try to understand what the stub is used for, and what length of stub you are expecting to end up with. Try to measure the load without the stub to determine the stub requirements.

When constructing a stub, the characteristic impedance ( $Z_0$ ) of the coax is not required to match the feed line, but the stub reactance depends on the stub  $Z_0$ , so the stub  $Z_0$  must be known.

The electrical length of a stub will be significantly shorter than the calculated length using the atmospheric formula. The RF waves travel slower in coax than in the air, so the expected stub length shortens by this factor. We use

the cable velocity factor (VF) in the calculation to account for this. You will need to know the stub cable's VF.

Decide what termination to use. The two choices are open or short. The short termination can result in a shorter stub, but short terminated stubs are usually less efficient due to  $I^2R$  losses. Also, shorted terminations are more difficult to tune.

Start with the stub length a little longer than expected. Record the initial reading. You may use Z angle, reactance, or gamma angle to tune the stub length. Snip off a small amount from the termination (open) end. Note the change in reading. Continue snipping until the desired reading is obtained. As experience develops, one can start with the length closer to the final length, and the amount of adjustments will drop. Beware that a different batch of cable can have a different VF, so prudence dictates the use of extra length on the first stub from a new reel of coax.

Summary of coaxial stub requirements:

1. Understand why the stub is needed.
2. Connectorize the unterminated end.
3. Determine stub  $Z_0$ .
4. Determine stub VF.
5. Determine stub termination.
6. Estimate the stub length needed.
7. Start with a slightly longer length.

### Making a Specific Length Stub:

1. Always start with a stub length longer than expected, then trim down to exact length.
2. Set up the network analyzer with adapters that mate to the stub connector.
3. Set the analyzer center frequency to the frequency of interest. Set the analyzer width and vertical scales to see a good picture of what's happening.
4. Set up the analyzer to measure one (or two) of the three plot types shown in the table below.
5. Cable null the analyzer with the adapters in place (open-short-load). The cable null removes connector and adapter errors, so the readings are of the stub and only the stub.
6. Note the reading at the frequency of interest.
7. Snip off small amounts from the termination end (open). If using shorted termination, make new short.
8. Repeat steps 6 and 7 until desired reading is obtained.

Length	Z angle	Reactance	Gamma angle ( $\theta$ )	Zero Xings
$\frac{1}{4}\lambda$	0 w/+slope	0	0 (rollover)	1 <sup>st</sup> zero Xing
$\frac{1}{2}\lambda$	0 w/-slope	0	0 (smooth)	2 <sup>nd</sup> zero Xing
$\frac{3}{4}\lambda$	0 w/+slope	0	0 (rollover)	3 <sup>rd</sup> zero Xing
$x\lambda$	N/A	Calc from Smith chart	$360 * (1/2 - \text{Fract}(2 * (x + 1/4)))$	Integer( $x * 4$ ) zero Xings
Notes	Limited to $N * 1/4\lambda$	$ X  < 300$ and $f < 30\text{MHz}$	Any length, any frequency	

Example: find a  $7/8\lambda$  line using gamma method.  $7/8 = x$  and the angle calculates to:

$$\begin{aligned} \theta &= 360 * (1/2 - \text{fract}(2 * (7/8 + 1/4))) \\ &= 360 * (1/2 - \text{fract}(2.25)) \\ &= 360 * (1/2 - 0.25) \\ &= 90 \text{ degrees} \end{aligned}$$

So we tune the stub for a gamma angle of +90. There will be  $\text{Int}(7/8 * 4) = 3$  zero crossings below the frequency of interest.

#### Notes:

1. The Z angle readings are limited to multiples of  $1/4\lambda$  lengths.
2. The reactance method can be used for arbitrary lengths, but works best if the reactance is between -300 and +300 ohms and the frequency is below 30MHz. You must determine the reactance value using the Smith chart.
3. The gamma angle method works well for any arbitrary length and any frequency range.
4. Readings repeat every  $1/2\lambda$ . There will be either a continuous or discontinuous zero crossing every  $1/4\lambda$ .

## Estimating Physical Cable Length for a Given Electrical Length:

$$L \text{ (in meters)} = 299.7924 * \lambda * VF / F$$

Or

$$L \text{ (in feet)} = 972.09 * \lambda * VF / F$$

$\lambda$  = electrical length in wavelengths.

F = frequency in MHz

VF = cable velocity factor

## Tuning an antenna stub:

1. Set up the network analyzer with adapters that mate to the feedline port on the coaxial Tee connector.
2. Set the analyzer center frequency to the frequency of interest. Set the analyzer width and vertical scales to see a good picture of the load.
3. Set up the analyzer to measure Z angle and reactance. **Do not use gamma angle.**
4. Cable null the analyzer with all the adaptors in place (open-short-load). The cable null removes connector and adapter errors, so the readings are the load at the feed line input.
5. Remove the stub and feed line from the coaxial Tee. Connect the analyzer to the antenna and take the reading. Note the reactive component of the reading.
6. Usually an antenna stub cancels out the reactance. The desired stub will have equal but opposite reactance to the reading in step 5. Calculate the expected length of the stub. Always start with a stub length longer than expected, then trim down to exact length. Add the appropriate connector to the stub.
7. Connect the stub to the Tee. If you chose the right starting length, the reactive component should now be slightly over compensated.
8. Note the reading at the frequency of interest.
9. Snip off small amounts from the termination end (open). If using shorted termination, make new short.
10. Repeat steps 8 and 9 until desired reading is obtained.

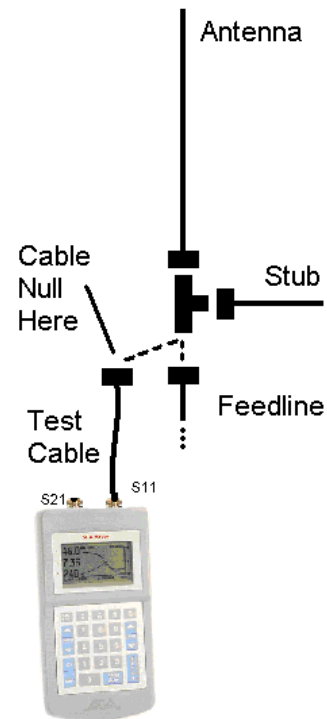

Using the Smith chart:

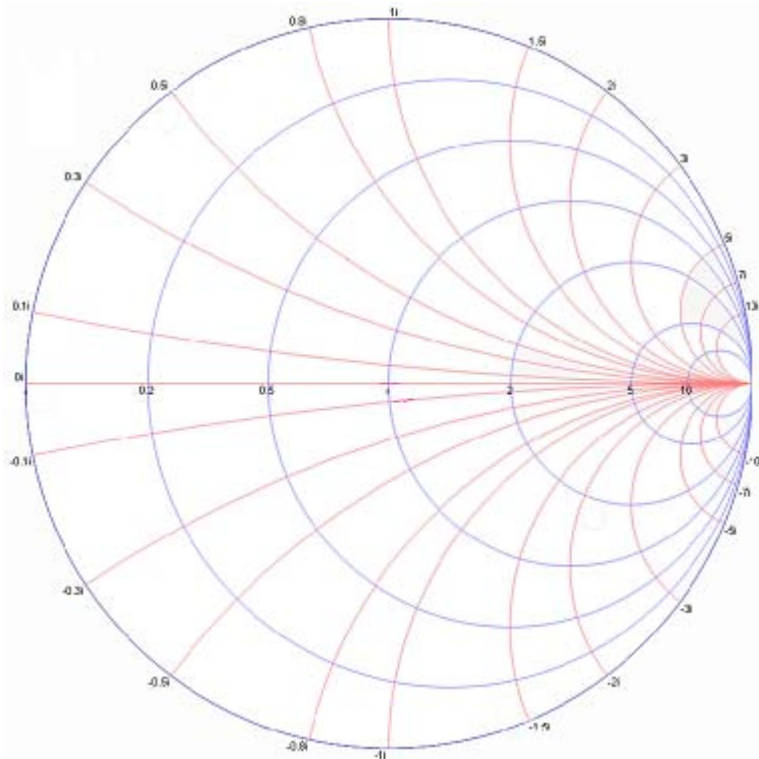

The Smith chart is shown above. More detailed Smith charts are available off the web or from University bookstores (if they have college of EE). The detailed versions will have the wavelength scale printed around the perimeter. When the stub is open terminated, start at the extreme right point (on horizontal line) of the chart (short terminations start at extreme left). One full trip around the chart is equal to  $1/2\lambda$ . Moving CCW from the starting point, move along the perimeter by the  $\lambda$  amount, or conversely, measure the  $\lambda$  required to reach the desired reactance.

$$\lambda \text{ (wavelengths)} = \theta / 720 \quad \text{or} \quad \theta \text{ (degrees around chart)} = \lambda * 720$$

The reactance  $X = +\text{or- } j * Z_0 * \text{ (normalized } X)$

The normalized  $X$  is read off the scale printed around the circumference. If the  $X$  is on the lower half, it is capacitive (expressed as a negative number). When  $X$  lies on the top half, it is inductive (and positive). The  $j$  term =  $\sqrt{-1}$ . Since the analyzer already separated the real portion from the imaginary, the displayed reactance just shows  $X = +\text{or- } Z_0 * \text{ (normalized } X)$ . Remember to multiply the Smith chart value by  $Z_0$  to match the reading on the analyzer. For a more detailed explanation of the Smith Chart, see our AN104: "Smith Chart 101".



## **Conclusion:**

AEA Technology network analyzers make tuning or measuring stubs an easy task to perform. The plot type used to measure the stub depends on the stub length and its application. The Smith chart is a tool that makes converting from stub length to stub reactance easy to do.